



PA and PT Irrigation Pump Sets

**Engines : TR1, TR2, TR3
LPW(S)2, LPW(S)3, LPW(S)4 and LPWT4**

**Pumps: SNM 50-160 up to SNM 150-200
(49–420 m³/hr)**

Air or Water cooled pump sets for operating conditions up to 52°C

The pump sets are designed to ensure optimum performance, taking into account standard operating site conditions.

For extreme site conditions (especially high altitudes), engine outputs after derating must be checked against the absorbed power by the pump.

Engine outputs used for the design of the pump sets are continuous ISO 3046 ratings under NTP conditions. The engine selection is made with at least 20% differential between the power absorbed by the pump and the engine output.



Lister Petter PT380L pump set (mobile configuration)

Standard Features

- LISTER PETTER TR air-cooled diesel engine
- Handle start
- LISTER PETTER ALPHA water-cooled diesel engine complete with engine control panel, low oil pressure and high water temperature protection, 12V battery and leads.
- Close coupling arrangement making very easy maintenance operations
- Suitable for ambient temperatures up to 52°C
- Suitable for tropical conditions
- Continuous operation for up to 24 hours a day
- Corrosion resistant galvanised base complete with forklift pockets (TR2/TR3 and LPW(S) 3/4/T4 only)
- 66 litres polypropylene fuel tank with contents gauge (TR2/TR3 and LPW(S) 3/4/T4 only)
- Engine mounted fuel tank (TR1: 13,5 L. and LPW2: 12 L.)
- Operators handbook



- Heavy Duty, single stage, centrifugal, end suction pump with cast iron casing and impeller
- Suction and Delivery flanges conforming with DN2533/PN16 – ISO7005-2/PN16
- Soft packed stuffing box used for shaft seal
- Hardened Chrome Steel shaft sleeve to protect pump shaft



Optional Items

- 12V electric start for TR series pump sets
- Off-road trailer with 2 wheeled axle, towbar and positioning stands (TR2/TR3 and LPW3/4/T4 only); Towing speed limited to 25km/hr maximum.
- Yard trolley kit (TR1 and LPW2)

Capabilities

See overleaf.

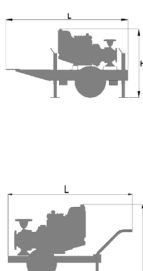
PA Approximate Dimensions and Weight (stationary configurations)					PT Approximate Dimensions and Weight (stationary configurations)						
Model	L Mm	W mm	H mm	Weight Kg			Model	L Mm	W mm	H mm	Weight Kg
PA130L	1225	580	752	300			PT130L	1225	580	739	295
PA145L	1225	580	752	305	PT145L	1225	580	739	300		
PA50M	1225	580	732	245	PT50M	1225	580	739	240		
PA60M	1225	580	732	255	PT60M	1225	580	739	250		
PA180L	1400	718	1048	385	PT180L	1400	718	978	375		
PA230L	1400	718	1098	425	PT230L	1400	718	1027	380		
PA90M	1400	718	1048	370	PT90M	1400	718	978	375		
PA310L	1400	718	1127	425	PT310L	1400	718	1027	425		
PA380L	1400	718	1157	465	PT380L	1400	718	1057	460		
PA420L	1400	718	1157	465	PT420L	1400	718	1057	460		
PA140M	1400	718	1127	440	PT140M	1400	718	1027	430		
PA190M	1400	718	1102	465							

PA Approximate Dimensions and Weight (mobile configurations)					PT Approximate Dimensions and Weight (mobile configurations)						
Model	L Mm	W mm	H mm	Weight Kg			Model	L Mm	W mm	H mm	Weight Kg
PA130L	1625	840	1022	315			PT130L	1625	840	1009	310
PA145L	1625	840	1022	320	PT145L	1625	840	1009	315		
PA50M	1625	840	1002	260	PT50M	1625	840	1009	255		
PA60M	1625	840	1002	270	PT60M	1625	840	1009	265		
PA180L	2202	1086	1308	485	PT180L	2202	1086	1235	475		
PA230L	2202	1086	1358	525	PT230L	2202	1086	1284	485		
PA90M	2202	1086	1308	470	PT90M	2202	1086	1235	460		
PA310L	2202	1086	1387	525	PT310L	2202	1086	1284	530		
PA380L	2202	1086	1417	565	PT380L	2202	1086	1314	560		
PA420L	2202	1086	1417	565	PT420L	2202	1086	1314	560		
PA140M	2202	1086	1387	540	PT140M	2202	1086	1284	535		
PA190M	2202	1086	1362	565							

Flanges Dimensions				
Pump model	Flanges Dia (mm)		Flanges Dia (inch)	
	Suction	Delivery	Suction	Delivery
SNM 50-160	65	50	2"1/2	2"
SNM 50-200	65	50	2"1/2	2"
SNM 65-250	80	65	3"	2"1/2
SNM 80-315	100	80	4"	3"
SNM 100-160	125	100	5"	4"
SNM 100-200	125	100	5"	4"
SNM 100-250	125	100	5"	4"
SNM 125-200	150	125	6"	5"
SNM 150-200	200	150	8"	6"

Fuel Consumptions	
Model	Consumption L/hr
PA130L	1,50
PA145L	1,60
PA50M	2,30
PA60M	2,00
PA180L	2,37
PA230L	3,13
PA90M	3,00
PA310L	3,90
PA380L	2,90
PA420L	3,70
PA140M	4,60
PA190M	5,50

Fuel Consumptions	
Model	Consumption L/hr
PT130L	1,20
PT145L	1,30
PT50M	1,84
PT60M	1,60
PT180L	2,57
PT230L	2,40
PT90M	3,20
PT310L	3,80
PT380L	3,60
PT420L	3,60
PT140M	4,30



UK

Lister Petter Limited, Dursley, Gloucestershire
 GL11 4HS England; Tel: +44 (0)1453 544141;
 Fax: +44 (0)1453 546732;

E-mail: sales@lister-petter.co.uk http://www.lister-petter.co.uk

Lister Petter have made efforts to ensure that the information in this data sheet is accurate but reserve the right to amend specifications and information without notice and without obligation or liability.